



Project _____

Item No. _____

Quantity _____

ELECTRIC STEAM KETTLE- PEDESTAL BASE

Model IEP-20	20 gallon (76 litre) electric pedestal base kettle
Model IEP-30	30 gallon (114 litre) electric pedestal base kettle
Model IEP-40	40 gallon (151 litre) electric pedestal base kettle
Model IEP-60	60 gallon (227 litre) electric pedestal base kettle
Model IEP-80	80 gallon (303 litre) electric pedestal base kettle
Model IEP-100	100 gallon (379 litre) electric pedestal base kettle



CONSTRUCTION

- 304 stainless steel construction
- 316 stainless steel liner for 20, 30, & 40 gallon
- 2/3 jacketed with factory sealed distilled water enclosure
- Hemispherical design on bottom of kettle for superior heat circulation
- Four 7/16" holes evenly spaced for securing unit to floor
- Stainless steel control housing
- Removable elements

OPERATION

- Electrically self-generated closed steam system
- Integrally mounted controls
- Power switch
- Thermostat
- Cook indicator light
- Pressure gauge
- Safety valve
- Low water light
- Low water shut off
- 165-285°F (74-140°C) temperature range
- 50 PSI maximum pressure

STANDARD FEATURES

- Manual control
- 2" tangent draw off
- Hinged cover for 20, 30, & 40 gallon
- Spring assist hinged stainless steel cover for 60, 80, & 100 gallon
- Standard voltage options
 - 208 VAC, 3 phase, 60 Hz
 - 240 VAC, 3 phase, 60 Hz
 - 208 VAC, 1 phase, 60 Hz (20 & 30 gallon models only)
 - 240 VAC, 1 phase, 60 Hz (20 & 30 gallon models only)
- One year parts and labor warranty

OPTIONS AND ACCESSORIES

(AT ADDITIONAL CHARGE)

Voltage options

- 220 VAC, 1 phase, 50/60 Hz (20 & 30 gal. only)
- 220 VAC, 3 phase, 50/60 Hz
- 380 VAC, 3 phase, 50/60 Hz
- 415 VAC, 3 phase, 50/60 Hz
- 480 VAC, 3 phase, 50/60 Hz
- 220/380 VAC, 3 phase, 4 wire, 50/60 Hz
- 240/415 VAC, 3 phase, 4 wire, 50/60 Hz
- 600 VAC, 3 phase, 60 hz

Power increase options

- 24 kW elements for 40, 60 & 80 gallon
- 33 kW elements for 60, 80 & 100 gallon

Faucets

- Single pantry faucet with swing spout
- Double pantry faucet with swing spout

Covers

- Two piece stainless steel hinged covers for 60, 80 & 100 gallon
- Spring assist hinged stainless steel covers for 20, 30 & 40 gallon

Draw off valves and accessories

- 3" (76 mm) draw off valve
- 2" (50 mm) dairy valve
- 3" (76 mm) dairy valve
- Perforated strainer for draw off
- Solid stainless steel disc for draw off valve

Etched markings

- Gallons
- Litres
- Correctional package
- 316 stainless steel liner for 60, 80 & 100 gallon
- Tri-basket assembly
- Graduated measuring strip
- Strainer hook



IEP | ELECTRIC STEAM KETTLE- PEDESTAL BASE

POWER CONNECTION:

Refer to data plate.

MAXIMUM PRESSURE:

All Models 50 PSI (345 kPa)

SHORT FORM SPECIFICATIONS

Provide Intek model IEP-20 (20 gallon), IEP-30 (30 gallon), IEP-40 (40 gallon), IEP-60 (60 gallon), IEP-80 (80 gallon) or IEP-100 (100 gallon) electrically heated pedestal base steam kettle. The controls shall be integrally mounted and shall include a power switch, thermostat with range of 165-285°F (74-140°C), a cook indicator light, pressure gauge, safety valve, low water light and low water shut off. The elements shall be removable. Unit shall have a 2" draw off valve. 20, 30 and 40 gallon units shall have a hinged, stainless steel domed cover. 60, 80 and 100 gallon units shall have a spring assist hinged stainless steel domed cover. The unit shall have a double wall interior to form a steam jacket around the lower 2/3 of the kettle. The jacket enclosure shall contain distilled water which is factory sealed. The bottom of the kettle shall be of hemispherical design for superior heat circulation. The kettle shall be supported on a pedestal base with 4 evenly spaced holes for securing to floor. Construction shall be of all welded satin finish 304 stainless steel. The interior of 20 through 40 gallon models shall be stainless steel type 316 for high acid content cooking. Unit shall be ASME code stamped and National Board registered. Provide options and accessories as indicated.

Available kW			AMPS PER LINE								
MODEL	STD.	OPT.	kW	PHASE	208V	220V	240V	380V	415V	480V	600V
IEP-20	12	N/A	12	1	57.7	54.5	50.0	N/A	N/A	N/A	N/A
IEP-30	15	N/A		3	33.3	31.5	28.9	18.2	16.7	14.4	11.6
IEP-40	18	24	15	1	72.1	68.2	62.5	N/A	N/A	N/A	N/A
IEP-60	18	24, 33		3	41.6	39.4	36.1	22.8	20.9	18.0	14.5
IEP-80	18	24, 33	18	3	50.0	47.2	43.3	27.3	25.0	21.7	21.7
IEP-100	24	33	24	3	66.6	63.0	57.7	36.5	33.4	28.9	23.1
			33	3	91.6	86.6	79.4	50.1	45.9	39.7	31.8

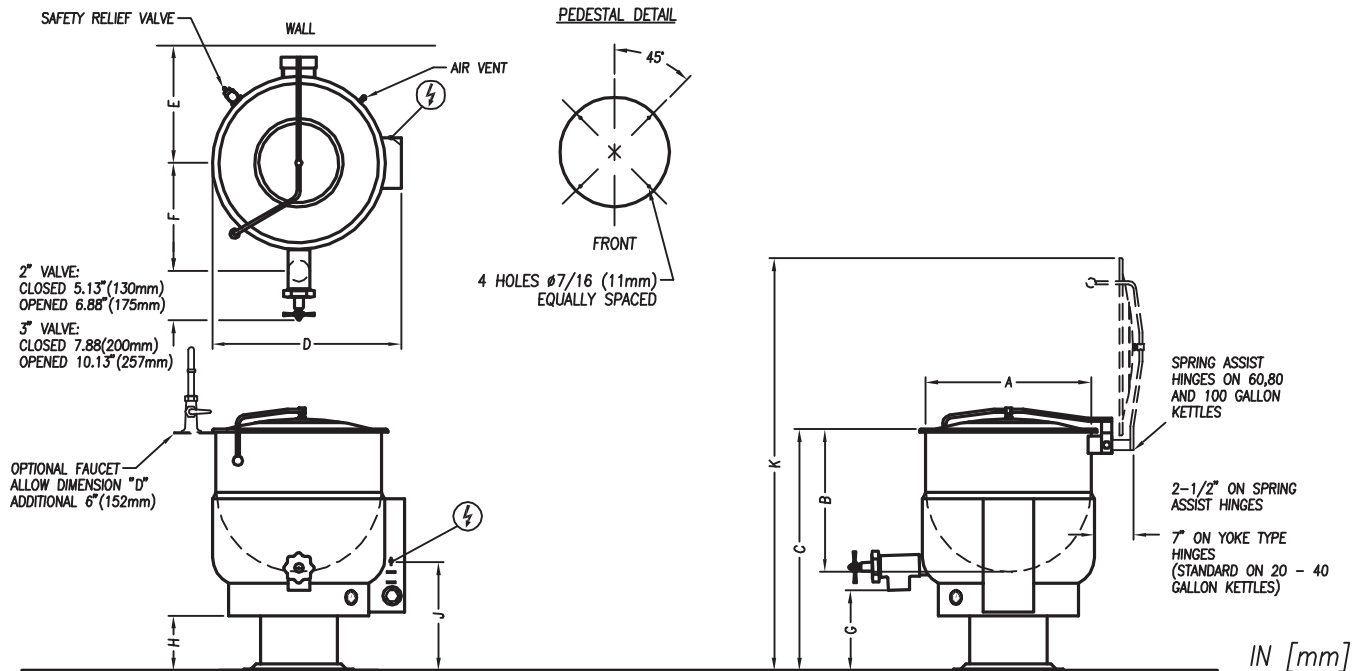

MODEL	A	B	C	D	E	F (2")	F (3")	G (2")	G (3")	H	J	K
IEP-20	21[533]	18[457]	38[965]	23.75[629]	18.5[470]	14.75[375]	15.5[395]	18[457]	17.5[445]	14[356]	21[533]	60.5[1537]
IEP-30	24[610]	20[508]	38[965]	27.75[705]	20[508]	16[406]	16.5[419]	15.75[400]	15.25[387]	12.5[318]	19[483]	63.5[1613]
IEP-40	26[660]	22.5[572]	38[965]	29.75[756]	21[533]	17[432]	18[457]	13.5[343]	13[330]	9[229]	17[432]	65[1651]
IEP-60	29.5[749]	26[660]	42[1067]	33.75[857]	19[483]	18[457]	19.25[489]	14[356]	13.5[343]	11[280]	17.25[438]	75[1905]
IEP-80	33[838]	28[711]	45[1143]	36.75[933]	20.5[521]	19.5[495]	20.5[521]	15[381]	14.5[368]	12.75[324]	18[458]	81[2058]
IEP-100	35.5[902]	30[762]	48[1219]	40[1016]	22[559]	21.5[546]	22.5[572]	15[381]	14.5[368]	13[330]	20.5[521]	87[2210]

INTEK MANUFACTURING, LLC

1300-D Airport North Office Park • Fort Wayne, IN • 46825

Sales: 800-875-1740 • Service: 877-482-7150 • Fax: 260-416-6120