



Project _____

Item No. _____

Quantity _____

DIRECT STEAM TRI-LEG KETTLE

- Model IDL- 125 125 gallon (473 litre) direct steam connected tri-leg kettle
- Model IDL- 150 150 gallon (568 litre) direct steam connected tri-leg kettle

SPECIFICATIONS:

Shall be an Intek Model _____, direct steam connected tri-leg kettle. A double wall interior shall form a steam jacket around the kettle. The bottom of the kettle shall be of hemispherical design for superior heat circulation. Kettle shall be mounted on four stainless steel tubular legs. Each leg shall be fitted with a 4 hole adjustable flanged foot for securing to the floor. Construction shall be all welded satin finish stainless steel type 304. The kettle interior shall be stainless steel type 304. Convenience features shall include a 2" (50mm) sanitary draw-off valve, a hinged flat split stainless steel cover.

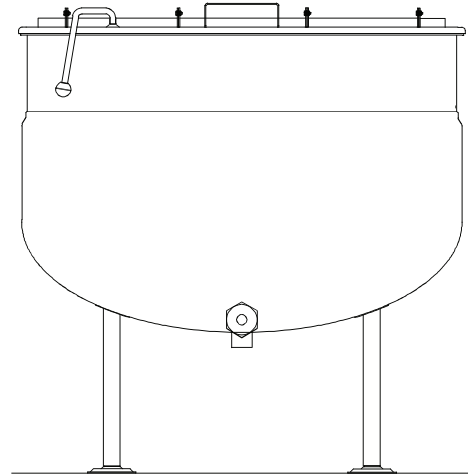

OPERATION SHALL BE BY:

Direct steam at a minimum of 5 PSI (34 kPa) and a maximum of 25 PSI (172 kPa) is required.



OPTIONS AND ACCESSORIES (AT ADDITIONAL CHARGE)

- Type 316 stainless steel liner for high acid content cooking
- 35 PSI (241 kPa) high pressure operation for higher cooking temperature
- 3" (76mm) draw-off valve
- 3" (76mm) dairy valve
- 2" (50mm) dairy valve
- Etched gallon markings
- Etched litre markings
- Single pantry faucet with swing spout
- Double pantry faucet with swing spout
- Correctional package
- Triple basket assembly
- Steam trap assembly
- Perforated strainer for draw-off valve
- Solid disc for draw-off valve
- Strainer hook
- Graduated measuring strip
- Steam control valve

IDL | DIRECT STEAM TRI-LEG KETTLE

SERVICE CONNECTIONS

☞ - STEAM SUPPLY: 3/4"(19mm)IPS. 25 PSI MAX. (35 PSI OPTIONAL)

Ⓒ - COLD WATER: 3/8" O.D. tubing to kettle fill faucet (OPTIONAL)

Ⓐ - CONDENSATE RETURN: 1/2"IPS

DIMENSIONS

MODEL	CAPACITY	UNITS	A	B	C	D	E	F	G	H	J	K	L
IDL-125	125 gallons	inches	42	28.75	43.75	44	12.43	22	27.5	36.12	28.75	12.0	86.12
	473 liters	mm	1067	730	1111	1118	316	559	699	918	730	305	2188
IDL-150	150 gallons	inches	42	33	48	44	12.43	22	27.5	36.12	29.88	12.0	90.38
	568 liters	mm	1067	838	1219	1118	316	559	699	918	759	305	2296

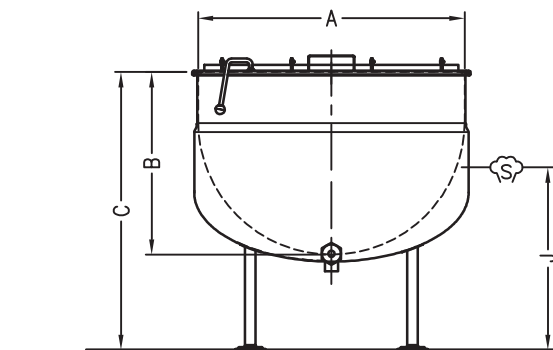
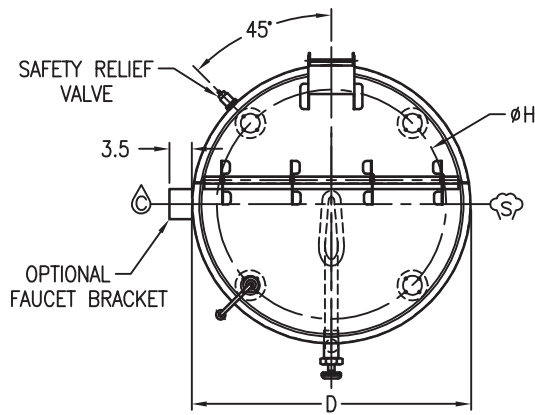

FLANGED FOOT DETAIL

4 EQUALLY SPACED
7/16" 11mm DIA. HOLES
ON 3" 76mm B.C.

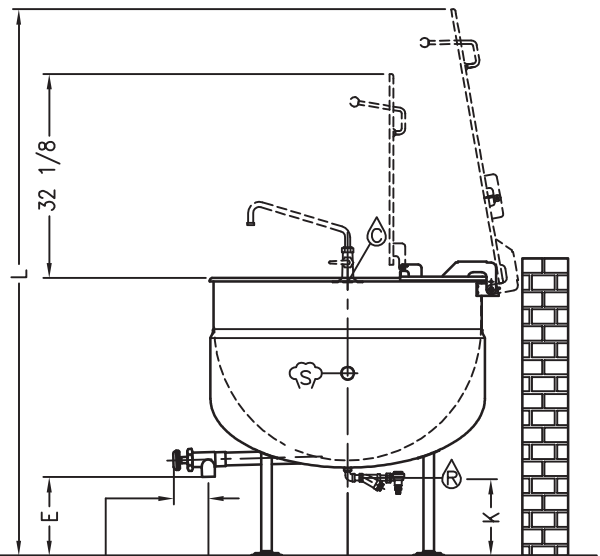

NOTE:
DIMENSIONS E AND F ARE BASED ON
Ø2" DRAW-OFF VALVE.

CLOSED 5.5" (140mm)
OPENED 7.5" (191mm)
BASED ON Ø2" TANGENT DRAW-OFF

DIMENSIONS ARE IN INCHES [MM]

INTEK MANUFACTURING, LLC

1300-D Airport North Office Park • Fort Wayne, IN • 46825

Sales: 800-875-1740 • Service: 877-482-7150 • Fax: 260-416-6120