



Project _____

Item No. _____

Quantity _____

DIRECT STEAM TRI-LEG STATIONARY KETTLE

- Model IDL-20 20 gallon (76 litre) direct steam kettle
- Model IDL-30 30 gallon (114 litre) direct steam kettle
- Model IDL-40 40 gallon (151 litre) direct steam kettle
- Model IDL-60 60 gallon (227 litre) direct steam kettle
- Model IDL-80 80 gallon (303 litre) direct steam kettle
- Model IDL-100 100 gallon (379 litre) direct steam kettle



CONSTRUCTION

- Water resistant construction
- 304 stainless steel construction
- 316 stainless steel interior cooking surface for added corrosion resistance for 20, 30 and 40 gallon
- 2/3 jacketed
- Hemispherical design on bottom for superior heat circulation
- Tubular stainless steel legs with flanged feet

STANDARD FEATURES

- 2" (50mm) draw off valve
- Hinged stainless steel counter balanced cover for 20, 30, & 40 gallon
- Spring assist hinged stainless steel cover for 60, 80, & 100 gallon
- Stainless steel faucet bracket
- One year parts and labor warranty



OPTIONS AND ACCESSORIES (AT ADDITIONAL CHARGE)

Etched markings

- Gallons
- Litres

Draw Off valves and accessories

- 3" (76mm) draw off valve
- 2" (50mm) dairy valve
- 3" (76mm) dairy valve
- Perforated strainer for draw off
- Solid stainless steel disc for draw off valve

Covers

- Two piece stainless steel hinged cover for 60, 80, & 100 gallon
- Spring assist hinged stainless steel cover for 20, 30, & 40 gallon

Faucets

- Single pantry faucet with swing spout
- Double pantry faucet with swing spout
- 316 stainless steel liner for 60, 80, & 100 gallon
- 50 PSI high pressure operation for higher cooking temperature
- Tri-basket assembly
- Strainer hook
- Graduated measuring strip
- Steam trap assembly consisting of steam trap, check valve, steam control valve, and line strainer
- Correctional package

IDL | DIRECT STEAM TRI-LEG STATIONARY KETTLE

PIPING REQUIREMENTS:

Steam supply 3/4" IPS
 Condensate Return 1/2" IPS

STEAM PRESSURE:

Minimum 5 PSI (34 kPa)
 Maximum 35 PSI (241 kPa) standard kettle
 50 PSI (345 kPa) optional high pressure kettle

Pressure reducing valve required if incoming steam pressure exceeds the kettle rating.

WATER SUPPLY:

Cold water 3/8" nominal tubing to optional pantry faucet

SHORT FORM SPECIFICATIONS

Provide Intek model IDL-20, 30, 40, 60, 80, or 100 gallon direct steam tri-leg stationary kettle. The unit shall have a double wall interior to form a steam jacket around the lower 2/3 of the kettle. The bottom of the kettle shall be of hemispherical design for superior heat circulation. Unit shall be mounted on stainless steel tubular tri-legs. Each leg shall be fitted with a four hole adjustable flanged foot for securing to the floor. Construction shall be all welded satin finish 304 stainless steel. 20, 30, 40 gallon models shall have a 316 stainless steel liner. Unit shall have a 2" draw off valve. 20, 30, and 40 gallon units shall have hinged, counterbalanced stainless steel domed cover. 60, 80 and 100 gallon units shall have a spring assist hinged stainless steel domed cover. The unit shall be ASME code stamped and National Board registered. Provide options and accessories as indicated.

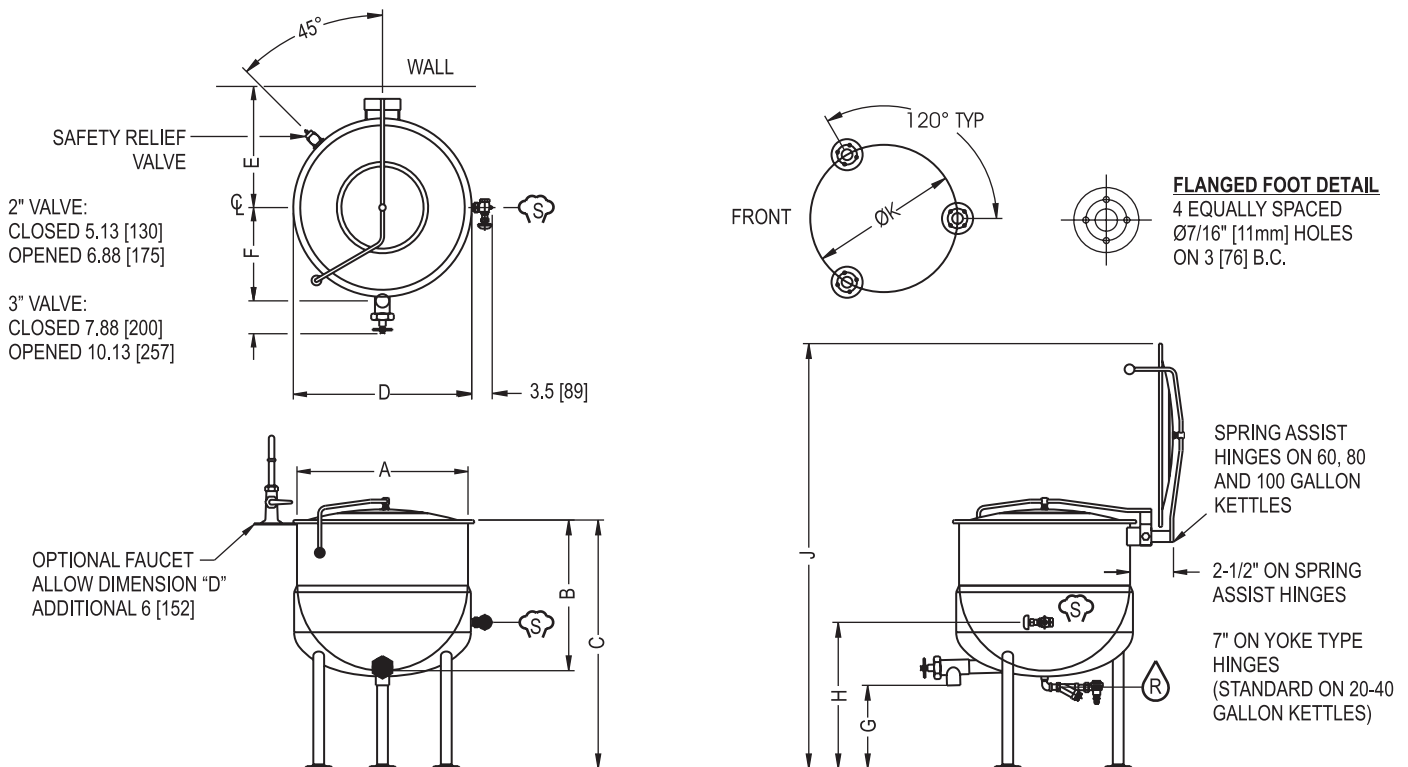

DIMENSIONS ARE IN INCHES [MM]

MODEL	A	B	C	D	E	F (2")	F (3")	G (2")	G (3")	H	J	K
IDL-20	21[533]	18[457]	37[940]	22.75[578]	16[406]	12.75[324]	14[356]	17[432]	16.5[419]	25.88[657]	59.75[1518]	17.5[445]
IDL-30	24[610]	20[508]	37[940]	25.88[657]	17.5[445]	13.5[343]	15.25[387]	15[381]	14.5[368]	26.88[683]	62.88[1597]	20.5[521]
IDL-40	26[660]	22.5[572]	37[940]	27.88[708]	18.5[470]	14.25[362]	16.5[419]	12.5[318]	12[305]	23.88[606]	64.88[1648]	22.5[572]
IDL-60	29.5[749]	26[660]	40.5[1029]	31.38[797]	17.75[451]	15.5[394]	17.25[438]	12.5[318]	12[305]	24.69[627]	72.88[1851]	25.75[654]
IDL-80	33[838]	28[711]	42.5[1080]	34.75[883]	19.5[495]	17.5[445]	19.25[489]	10.5[267]	10[254]	23.88[606]	75.25[1911]	29.25[743]
IDL-100	35.5[902]	30[762]	44.5[1130]	37.25[946]	20.75[527]	17[432]	19.25[489]	12.5[318]	12[305]	26.63[676]	81.75[2076]	31.75[806]

INTEK MANUFACTURING, LLC

1300-D Airport North Office Park • Fort Wayne, IN • 46825

Sales: 800-875-1740 • Service: 877-482-7150 • Fax: 260-416-6120